



MEGA FORTRIS
G R O U P

INDICATIVE SEAL

MEGA TWISTER SP (MTW SP) MEGA TWISTER SP - PP (MTW SP - PP)

Application Seal

Extensive range of designs for a variety of identifying purposes.

The Mega Twister SP seal range consists of multiple identifier placement options to accommodate different requirements. Their simple locking mechanism makes the seals user-friendly and versatile for different applications. Mega Twister SP has a translucent body for quick inspection of the twister insert sealing, where colour coded inserts and its ample identifier marking area eases operations. Conversely, Mega Twister SP - PP has a polypropylene coloured body which is designed to be chemical resistant. The seal is small in size and versatile for any securing and identifying purposes. These seals include the BioSphere bio-additive.

To provide eco-conscious solutions on a wide array of applications, all Mega Fortris' security seal product lines with plastic content will include the BioSphere bio-additive from 13th May 2024.

Applications:

- Utility Meters & Scales
- Chemical and Oil Refinery
- Transportation
- Banking



Our biodegradable plastic additives go deeper, allowing microbes to consume the C-C bonds within plastic's structure at a macromolecular level. This increases the surface area of plastic products and enables plastophilic microbes to attach to the polymer's newfound cavities. So, unlike regular plastic that can sit in a landfill for hundreds or thousands of years, plastic enhanced with BioSphere attracts over 600 different types of microbes that effectively digest and consume it.

PREVENTION · PROTECTION · PEACE OF MIND





Mega Twister SP (MTW SP)



Mega Twister SP - PP (MTW SP - PP)

LASER MARKING OPTION

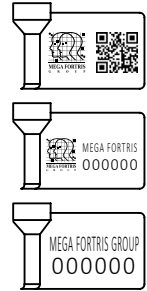

VIEW APPLICATION GIF



- 1 The Mega Twister SP is produced with a frosted-coloured body and a twister locking insert. The frosted-coloured plastic body is translucent and allows a clear view of the locking and evidence of tampering.
- 2 Mega Twister SP - PP comes with a coloured body and is designed to be chemical resistant.
- 3 The standard wire for various applications is stainless steel (SS) coated wire. Other wire types are available upon request. With the wires, the twister locking mechanism ensures quick and tight securing of the security seals.
- 4 A marking area flap is placed on the side for irreversible laser marking of identifiers such as name, logo, barcode, serial number and QR code.
- 5 For Mega Twister SP, colour coding is possible with a combination of the frosted plastic body and our offered colour choices for the vibrant colour insert.
- 6 For Mega Twister SP - PP, colour coding is possible with a combination of our offered colour choices for the body and white insert.
- 7 Special UV additives for the product's long-lasting performance are available.
- 8 These seals include the BioSphere bio-additive.

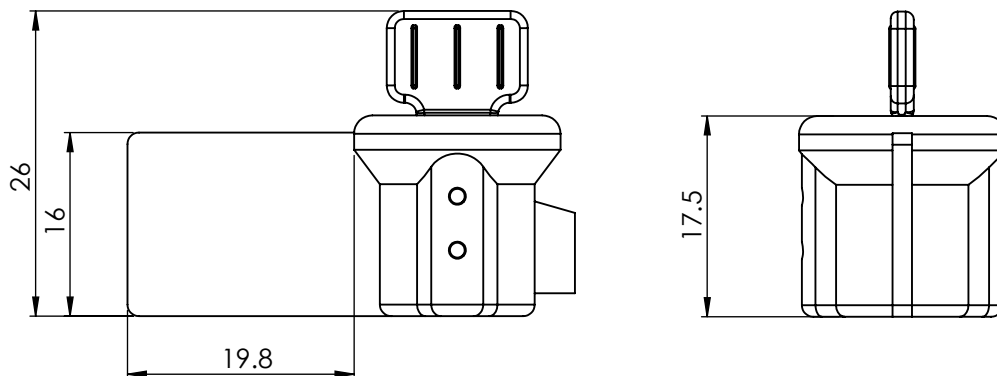

Updated Date : 26 November 2024

TECHNICAL SPECIFICATIONS

PRODUCT - MEGA TWISTER SP (MTW SP) & MEGA TWISTER SP - PP (MTW SP - PP)						
Code	Material	Locking Length	Locking Size	Tensile Strength	Marking Area	Max Marking Digits
MTW SP	Plastic body: Polycarbonate (PC) <i>Temperature Range:</i> -40°C to 85°C Plastic insert: Acetal (POM) <i>Temperature Range:</i> -40°C to 120°C Cap: Acrylonitrile Butadiene Styrene (ABS) <i>Temperature Range:</i> -20°C to 120°C Cable: Plastic-coated Stainless Steel 304 (SUS 304)	250 mm (9.8 in)	Ø2.5 mm (0.098 in)	>30 kgf (>66 lbf)	8 x 12 mm (0.31 x 0.5 in)	Serial no : 6
	Plastic body: Polypropylene (PP) <i>Temperature Range:</i> -20°C to 120°C Plastic insert: Acetal (POM) <i>Temperature Range:</i> -40°C to 120°C Cap: Polypropylene (PP) <i>Temperature Range:</i> -20°C to 120°C Cable: Plastic-coated Stainless Steel 304 (SUS 304)				14 x 17 mm (0.6 x 0.7 in)	Serial no : 6 Barcode : 6

PACKAGING					Standard Colours
Carton	Quantity	Dimensions (mm)	Gross Weight (kg)	Volume (m³)	
MTW SP Inner	1000 Pre-cut wire	338 x 255 x 190 mm (13.3 x 10 x 7.5 in)	4.68 (10.3 lb)	0.016 (0.565 cu. ft.)	MTW SP Body : <input type="checkbox"/> TR <input type="checkbox"/> FR Cap : <input type="checkbox"/> WH Insert : <input type="checkbox"/> WH <input type="checkbox"/> YL <input type="checkbox"/> OR <input type="checkbox"/> GN <input type="checkbox"/> RD <input type="checkbox"/> BL <input type="checkbox"/> BK
MTW SP - PP Inner	500 Twisted wire <45cm	465 x 260 x 190 mm (22.4 x 9.3 x 7.1 in)	TBC (TBC lb)	TBC (TBC cu. ft.)	MTW SP - PP Body : <input type="checkbox"/> WH <input type="checkbox"/> PSYL <input type="checkbox"/> PSOR <input type="checkbox"/> PSRD <input type="checkbox"/> PSBL <input type="checkbox"/> PSGN <input type="checkbox"/> BK Cap : <input type="checkbox"/> WH Insert : <input type="checkbox"/> WH

For colour customisations, kindly contact us for further information.

Updated Date : 26 November 2024